

Helping Hands

[1012 Aurthur Stiles
Road]
[(512)435-7464]

Business Plan

Prepared By: Helping Hands

2011

HELPING HANDS



Executive Summary

Executive Summary

Social Mission Statement

“Changing the world one panel at a time.”

Service Description

Provide the colonias with electricity.

Target Customers

Our target customer is anyone living in colonias. In addition, our solution would apply to off the grid customers. Off the grid means that they are not connected to the network. This means they do not have a electricity provider.

Market Description

In this market there are plenty of customers. This is because there are over 400,000 colonias in Texas. This is why our solution is something that will benefit plenty of people.

Project Description

The main components of our project are the solar panels. We will use solar panels to power 15 houses in La Presa outside of Laredo, Texas. Each house will have a limit to the load they can use. The load calculation will give them freedom to have additional appliances.

Table Of Contents

Helping Hands

Table of Contents

“Changing the world one panel at a time”

- i. Executive Summary... Pg. 3-4
- ii. *Company Profile... Pg. 8*
- iii. Project Description... Pg. 10-12
- iv. *Target Market... Pg. 14-15*
- v. Financials... Pg. 17-19
- vi. *Management and Organization...
Pg.21-22*
- vii. Appendices... Pg.24

Company Profile

Company Profile

Company Name:

Helping Hands

Company Mission:

“Changing the world one panel at a time.”

Our Purpose:

Velocity Prep is four week program that gives high school students the opportunity to explore different careers. Our Employer is Dr. Dean Schneide, of Texas Engineering and Experimental Station(TEES). Our Task was to design a system that would provide the La Presa colonia with electricity. Colonias are illegally subdivided lots.This happened because of the developers. They never consulted the state if the properties were up to standard. They are off-grid which means they do not have electricity, running water, or waste removal.

Company Logo:



Target Market

Target Market

Target Market

The target market for this project are people that lack basic utilities. Another target market are off the grid installations.

Colonias

Colonias are communities along the U.S-Mexico border. They lack the essential utilities such as water, electricity, and waste removal to name a few. Colonias are usually illegally subdivided properties. Most of homes in the colonias do not have clean titles. This means that most of the families living there do not own the property and were made to believe that they would in a couple of years. This means that the land that is part of a colonia may not be able to receive utilities from the city utility companies.

Problems Being Faced

Colonias typically face problems because of utility complications. This may mean they lack necessities such as running water, electricity, and waste management.

Need For Solution

There is a need for this solution because it would help improve their quality of living. They would also be able to afford having things we considered basic

which for them are luxuries. Some of these luxuries are things like refrigerators, ceiling fans, and small A/C units.

Competitive Analysis

Our only current competition in this market are generators. However, generators are not always available and will cost much more than the electricity provided by our solution.

Project Description

Project Description

Project Goal and Components

The goal of this project is to provide colonias with 24/7 electricity. This system will power 15 homes. Each house will have nine solar panels and all nine panels will be on one mount. There are many components to our solution, which are listed in the table below. This table includes price, components, brands, and quantity.

Equipment	Qty.	Cost	TOTAL
Suntech Monocrystalline 185W Solar Panels	135	\$ 469.00	\$ 63,315.00
Concorde PVX-1040T Sun-Xtender	90	\$ 294.20	\$ 26,478.00
UniRac Solar Panel Mount 10	14	\$ 965.00	\$ 13,510.00
Midnight Solar Battery Enclosure 12	7	\$ 629.16	\$ 4,404.12
Sunny Island 5048	4	\$ 4,111.80	\$ 16,447.20
Outback Flexmax 60 Solar Charge Controller	4	\$ 559.00	\$ 2,236.00
Midnight Solar Battery Enclosure 6	1	\$ 357.00	\$ 357.00
Labor	1	\$ 20,000.00	\$ 20,000.00
Wiring (Inverters, System, Solar Panels)	1	\$ 42,016.00	\$ 42,016.00
Other (Fencing)	1	\$ 8,656.00	\$ 8,656.00
Shipping Container	1	\$ 1,995.00	\$ 1,995.00
Other Hardware	1	\$ 9,000.00	\$ 9,000.00
Cable Poles	5	\$ 10,000.00	\$ 50,000.00
TOTAL	246	\$ 2,357.36	\$ 258,414.32

Benefits

There are many benefits to our solution such as:

- Mounts on ground: This is a benefit because there will not be a security issue.

- Expands with each additional source of energy
- Function independently from one another. This means that if one panel is damaged it will not affect any other one.
- It's scalable

Research and Development

Most of our research was done using company professionals such as Austin Energy, Mavrick Solar and websites similar to that. We used were books for wiring to make sure everything would turn out how we wanted it. We had many ideas for a solution before we settled on one particular one. The idea we had before this included wind turbines, that would help produce electrical power. We realized that turbines would only produce very little energy. This led us to choose only solar energy.

The Future of Our Solution

There are many possibilities for the future with our project. Our cable will be expandable from one phase to three phases that will allow for greater demand when it occurs. Adding a phase will allow TEES to serve a system of 30 homes. When the system becomes more develop houses with suitable roofs will be allowed to have solar panels so they can provide energy to the network. If possible, houses will be equipped with smart meters so it will give people control of the amount of energy used. It will allow the client to monitor electricity use. The purposes of these meters are so the client

will be able to shut power down whenever it becomes too much energy is being used. Implementing micro smart grid will make energy dispersal more efficient.

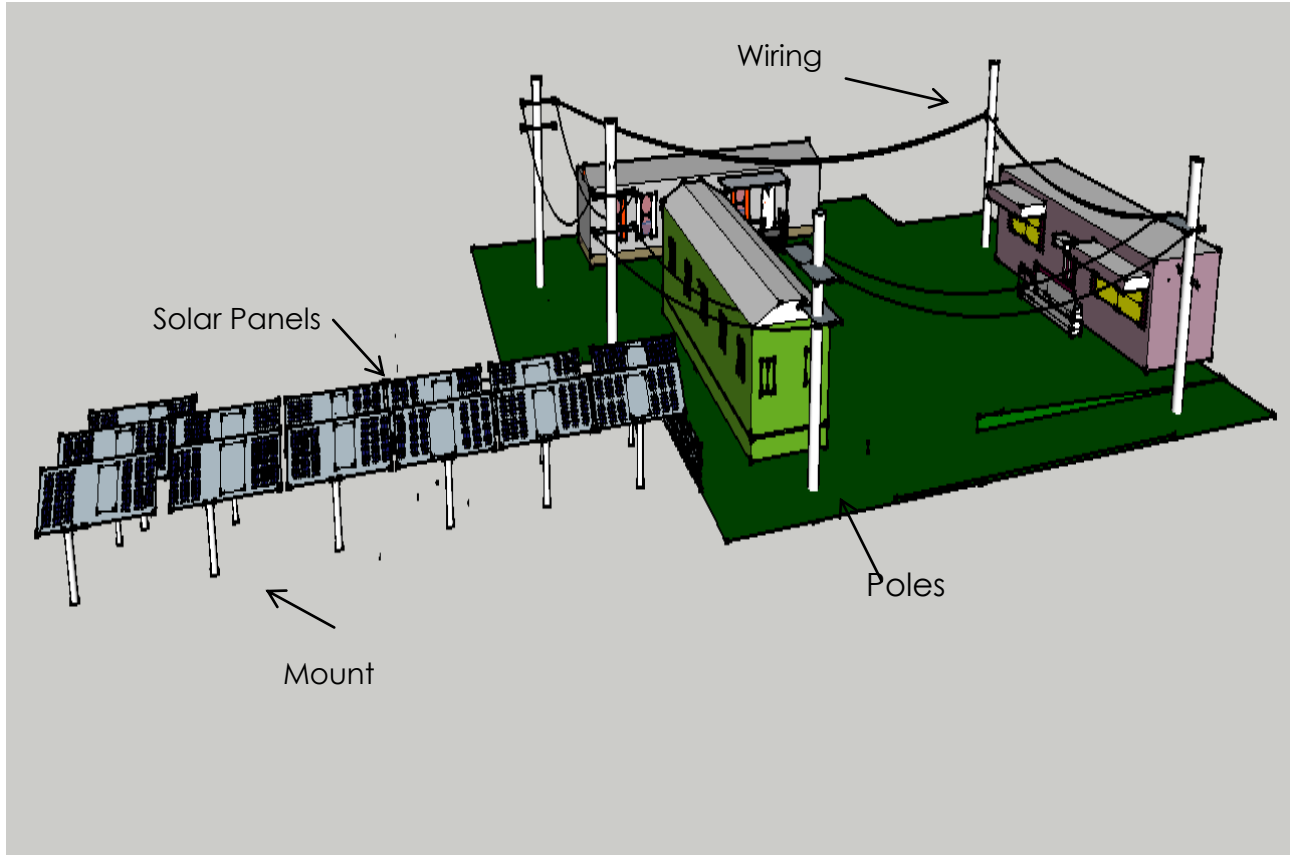

Financials

Financials

Overall cost

\$258,414.32

Projections

These projections are for the next five years. The graphs represent how much the people in the colonias would be charged per kWh.

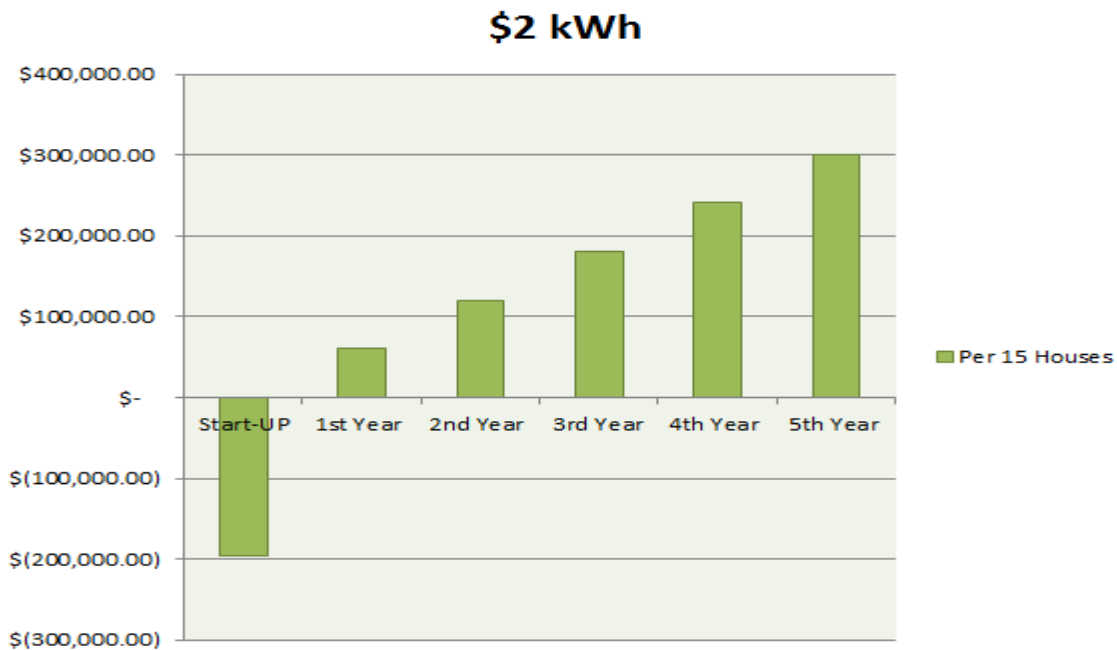

This graph shows the income over the next five years if the colonias were being charged \$2 a KWH. The breakeven point for TEES would be between the third or fourth year. The next chart show the exact same thing only when they are charged \$3.

\$3 kWh

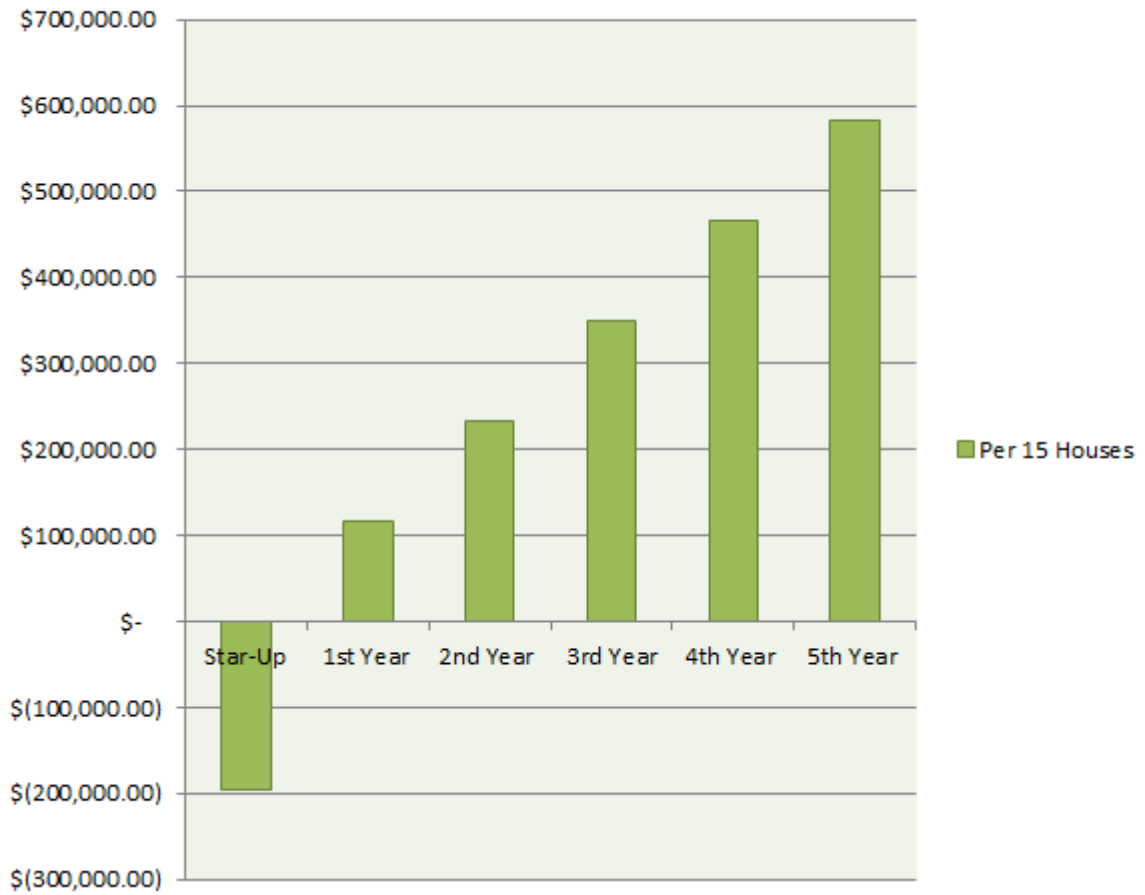

Maintenance

The maintenance part of our project will be fairly simple because maintenance would only be for batteries. The maintenance would be done by hopefully someone who lives in the colonias. This person would be trained by TEES and would know what to do.

Market plan

There would allow them to have a small freezer something that they cannot afford to power with a diesel generator. This would make their life a lot simpler.

Recommended Pricing

We believe it would be best if we charged \$2-\$3 per KWh. The reasoning behind this is because the payback of this project would be sooner than the 5 years expected. We believe we should do this because after the 5 year period we would lower the cost from two to three dollars to less. Our pricing will be attractive to people in the colonias because cost will not change but they will be able to have a bigger load. They would also be able to have energy 24/7.

*Management &
Orginaization*

Management & Organization

Darriyan Kent:

Role: C.E.O. for Helping Hands

Duties: Make sure work is being completed, Lead team, Help with the decision making process

Richard Torres:

Role: Engineering Sub-Leader

Duties: Come up with ideas for a solution, Research components of solution, Prepare Budget

Maleeca Smith:

Role: Presentation

Duties: Prepare Presentation

Jennifer Garza:

Role: Presentation

Duties: Go through presentation and be able to present information to clients

Sherrod Jackson:

Role: Solution Design

Duties: Create a design for the solution, Use Sketch-Up

Elizabeth Garcia:

Role: Video

Duties: Create and edit video

Miriam Delgado:

Role: Business Plan

Duties: Create business plan for our design

Organizational Chart

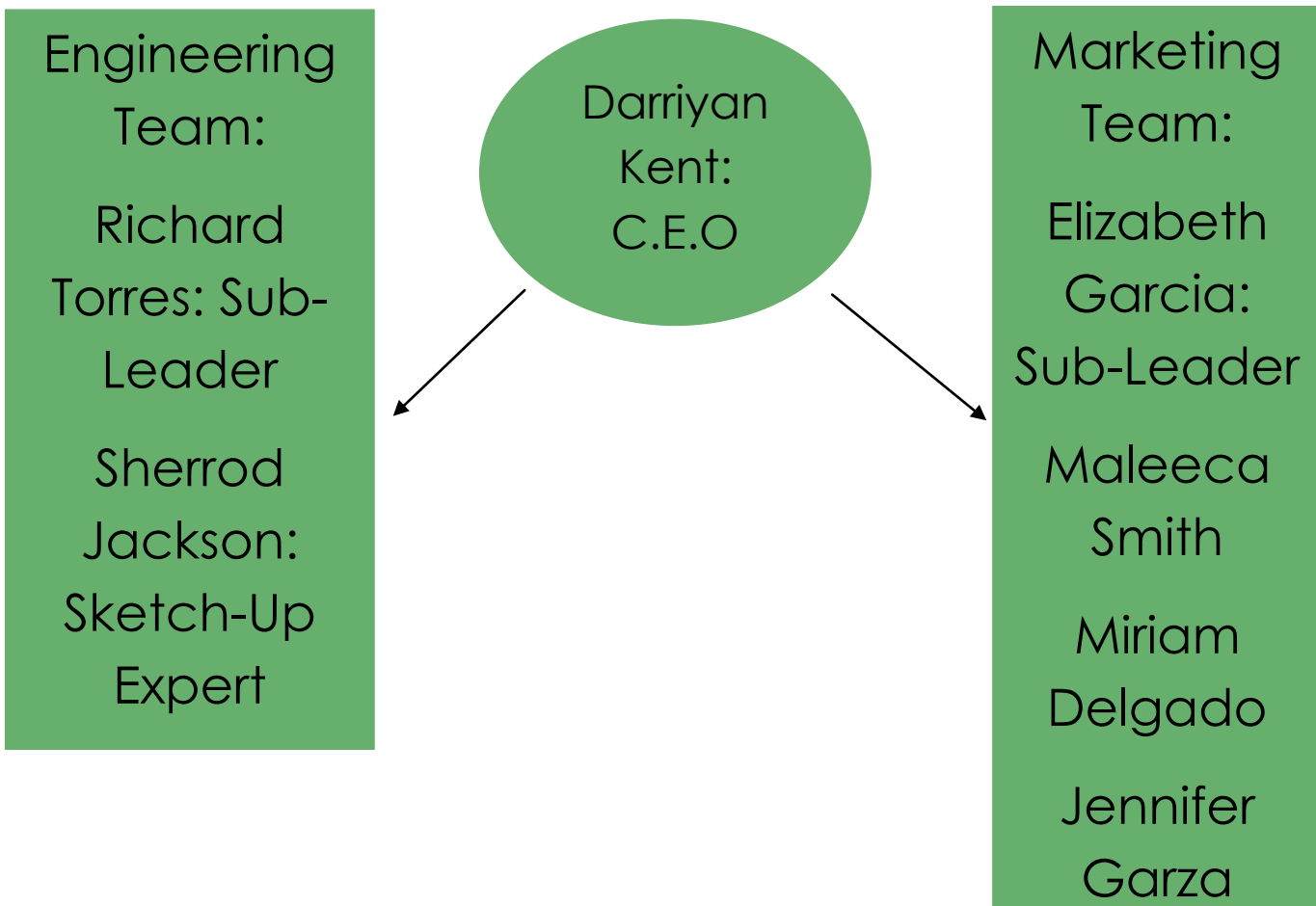

Appendices

Appendices

- i. Company Biographies
- ii. Sketch-Up Design
- iii. Slogan
- iv. Mission Statement
- v. Components List
- vi. Wiring Diagrams

i. Helping Hands Company

Biographies:

Darriyan Kent



I am 15 years old and I am currently a Junior at Eastside Memorial Green Tech. I consider myself a dedicated person to all things that I do.

Richard Torres



I am 16 years old and I really enjoy things to do with Computers, another fun fact about me is that I was born in South Carolina.

Maleeca Smith



I am 16 years old and I was born in El Paso, Texas, and the reason why I applied for this job was because I wanted to try something new.

Jennifer Garza



I am currently 17 years old and I'm the type of person that loves to learn new things that is why I decided to apply for this job.

Sherrod Jackson



I am 17 years old. I enjoy sports and school, I like to try things I never tried so that's why I applied for this job and I like it.

Elizabeth
Garcia



I am 16 years old and I was born in Laredo, Texas. I'm the type of person that really enjoys reading. My favorite book is called "The Hunger Game"

Miriam
Delgado



I am 16 years old; I'm currently a Junior at Eastside Memorial. I Enjoy working with other people. I applied for this job because I wanted to help less fortunate people.

ii. Sketch-Up Design:

This is what we would like the actual desing to look

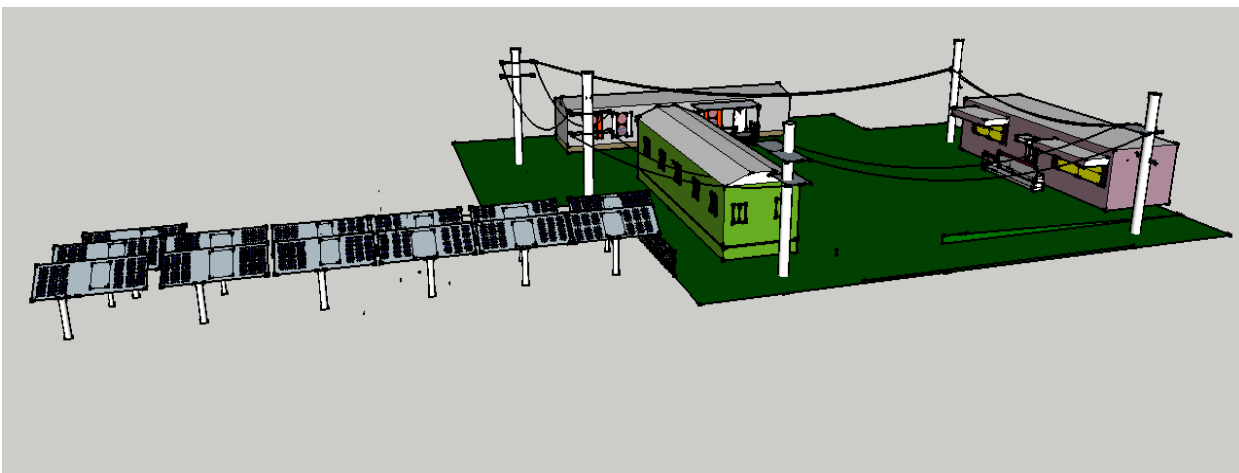

iii. Slogan:

“Keeping it sunny!”

iv. Mission Statement:

“Changing the world one panel at a time.”

v. Components List

Suntech 185W Solar Panels

<http://www.altestore.com/store/Solar-Panels/Suntech-STP185S-24Adb-185W-24V-Solar-Panel/p8224/>

Concorde PVX-1040T Sun-Xtender

<http://stores.mavericksolar.com/-strse-213/Concorde-PVX-dsh-1040T-Sun-dsh-Xtender-12V/Detail.bok>

Midnight Solar Battery Enclosure 12

<http://www.altestore.com/store/Deep-Cycle-Batteries/Enclosures-for-Deep-Cycle-Batteries/Cabinet-Style-Battery-Enclosures/Midnite-Solar-MNBE-E-12-Battery-Enclosure-Group-31/p7897/>

Sunny Island Inverter

<http://www.centrix-intl.com/details.asp?productid=10185>

Outback Flexmax 60 Solar Charge Controller

<http://www.altestore.com/store/Charge-Controllers/Solar-Charge-Controllers/MPPT-Solar-Charge-Controllers/Outback-Solar-Charge-Controllers-MPPT/Outback-Flexmax-60-Solar-Charge-Controller/p6875/>

Midnight Solar Battery Enclosure 6

<http://www.altestore.com/store/Deep-Cycle-Batteries/Enclosures-for-Deep-Cycle-Batteries/Cabinet-Style-Battery-Enclosures/Midnite-Solar-MNBE-A-6-Battery-Enclosure-Group-31/p3974/>

Unirac Mounts

<http://www.altestore.com/store/Solar-Panel-Mounts-Trackers/Top-of-Pole-Solar-Mounts/Unirac-Top-Of-Pole-Mounts/Unirac-Poletop-25-Channel-24/p5260/>

vi. Wiring Diagrams

Wiring Diagram For 1 Array of Solar Panels

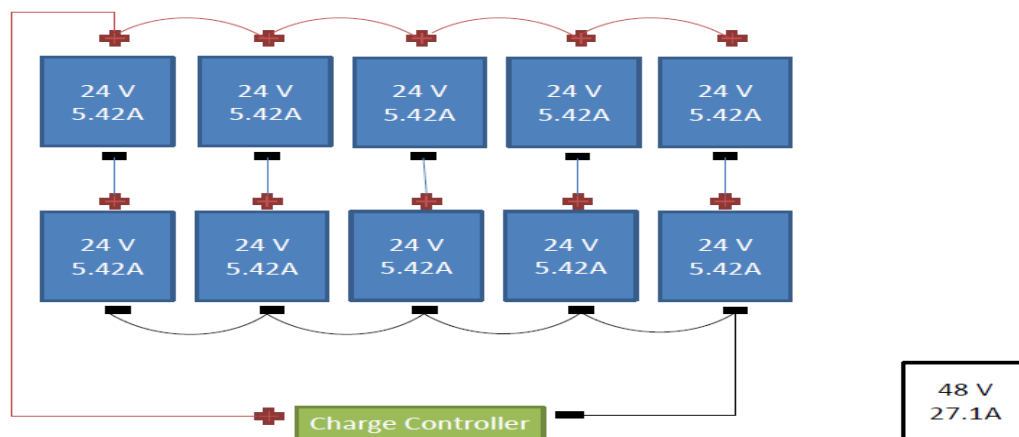

Wiring Diagram For Array of Batteries

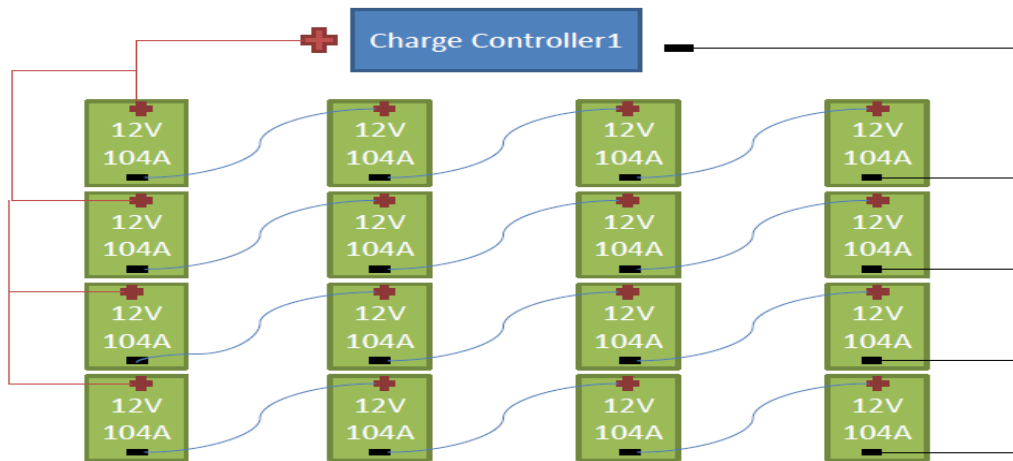

48V
416A

*Continues for all batteries
* Series/Parallel

Wiring Diagram For Entire Array of Solar Panels

